

CONTENTS

IFC Straight & Level

AirVenture 2009 proved to be not only an awesome event, but also a wildly successful one! by Geoff Robison

2 News

4 EAA AirVenture 2009 Awards

6 Yah, Dat Be a Swedish Ahrplane

Lars de Jounge's Saab Safir
by Budd Davisson

12 Lucky Lady—One Simply Splendid Stearman

Brought to you by the restorer and the reluctant pilot
by Sparky Barnes Sargent

18 It Does Matter

The mission is simple
by Brian Kissinger

23 Light Plane Heritage

The Driggs Dart I
by Jack McRae

26 Friends of the Red Barn Thank You

28 The Vintage Mechanic

Breaking in a radial engine
by Robert G. Lock

34 The Vintage Instructor

Whose Rules
by Doug Stewart

36 Mystery Plane

by H.G. Frautschy

39 Classified Ads



6



12

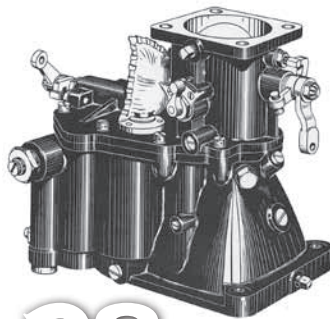

28

STAFF

EAA Publisher Tom Poberezny
Director of EAA Publications Mary Jones
Executive Director/Editor H.G. Frautschy
Production/Special Project Kathleen Witman
Photography Jim Koepnick
Bonnie Kratz

Advertising Coordinator Sue Anderson
Classified Ad Coordinator Lesley Poberezny
Copy Editor Colleen Walsh
Director of Advertising Katrina Bradshaw

Display Advertising Representatives:
Specialized Publications Co.

U.S. Eastern Time Zone-Northeast: Ken Ross
609-822-3750 Fax: 609-957-5650
kr40@comcast.net

U.S. Eastern Time Zone-Southeast: Chester Baumgartner
727-532-4640 Fax: 727-532-4630
cbaum111@mindspring.com

U.S. Central Time Zone: Gary Worden
800-444-9932 Fax: 816-741-6458
gary.worden@spc-mag.com

U.S. Mountain and Pacific Time Zones: John Gibson
916-784-9593 Fax: 510-217-3796
john@spc-mag.com

Europe: Willi Tacke
Phone: +49(0)1716980871 Fax: +49(0)8841 / 496012
willi@flying-pages.com

COVERS

FRONT COVER: Lars De Jounge has always had a knack for finding wonderful unusual aircraft, and his 1961 Saab Safir certainly fits that bill. Read more about the Safir in Budd Davisson's article starting on page 6. EAA photo by Bonnie Kratz.

BACK COVER: Jeanne Reed flies it, Pete Reed restored it—their 1943 Boeing Stearman N2S-5 is one beautifully customized biplane, powered by a 300-hp Lycoming wrapped in a Beech AT-10 cowl. The Reeds, who make their home in Florida, worked together to make it possible to keep flying after Pete lost his medical certificate. Read about their solution in Sparky Barnes Sargent's article, which begins on page 12. EAA photo by Jim Koepnick.